

# H59550

Istruzioni di montaggio  
Assembly instructions  
Instructions de montage  
Montageanleitung  
Instrucciones de montaje

**IT** Le presenti istruzioni di montaggio costituiscono parte integrante delle istruzioni per l'uso dell'unità, le quali sono il principale riferimento per qualsiasi intervento di installazione, manutenzione e ispezione.

**EN** These fitting instructions are an integral part of the instructions for use of the units, which are the prime source of information on every operation of installation, maintenance and inspection.

**FR** Les présentes instructions de montage font partie intégrante des instructions d'utilisation d'unité, lesquelles constituent le document de référence pour toute interventions d'installation, d'entretien et de contrôle.

**DE** Die vorliegenden Montageanleitungen sind wesentlicher Bestandteil der Gebrauchsanweisungen der Geräte, welche die Hauptunterlagen für Aufstellung, Wartung und Kontrolle der Einheit darstellen.

**ES** Las presentes instrucciones de montaje constituyen parte integrante de las instrucciones para el uso de la unidad y son la principal referencia para toda intervención de instalación, mantenimiento e inspección.



**ATTENZIONE!**

L'installazione degli accessori deve essere eseguita esclusivamente da tecnici esperti abilitati ad operare su questa tipologia di prodotti.



**ATTENTION!**

The installation of the accessories must be undertaken exclusively by expert technicians qualified to work on this type of product.



**ATTENTION!**

L'installation des accessoires doit être confiée exclusivement à des techniciens qualifiés autorisés à intervenir sur ce type de produit.



**ACHTUNG!**

Die Installation des Zubehörs darf ausschließlich von Fachkräften vorgenommen werden, die nachweislich zu Arbeiten an solchen Produkten befähigt sind.



**¡ATENCIÓN!**

La instalación de los accesorios debe ser realizada exclusivamente por técnicos expertos capacitados para trabajar con esta tipología de productos.

## SAM

**ISTRUZIONI DI MONTAGGIO SAG:** *Kit supporto antivibranti*

**SAG ASSEMBLY INSTRUCTIONS:** *Antivibration support kit*

**INSTRUCTIONS DE MONTAGE SAG:** *Kit supports anti-vibrations*

**MONTAGEANLEITUNG FÜR SAG:** *Bausatz Schwingungsdämpfer*

**INSTRUCCIONES DE MONTAJE SAG:** *Kit soportes antivibrantes*

## IT Istruzioni di montaggio dei supporti antivibranti

L'unità può essere dotata di kit supporti antivibranti a gomma.

- Allontanare dalla zona di lavoro le persone estranee;
- accertarsi che la macchina non sia alimentata elettricamente;
- sollevare l'unità seguendo le indicazioni riportate nel manuale di uso e manutenzione della stessa;
- adagiare l'unità su solidi supporti in grado di reggerne il peso;
- individuare l'unità ed il tipo supporti antivibranti;
- posizionare con la massima cautela l'unità nella sua sede.

## EN Antivibration mountings assembly instructions.

The unit may be provided with rubber antivibration mountings kit.

- Ask all unauthorized personnel to leave the area;
- Make sure that the machine is disconnected from the mains;
- Lift the unit, following the instructions in its use and maintenance manual;
- Rest the unit on solid supports able to bear its weight;
- identify the unit and the type of antivibration mountings;
- put the unit into place with maximum care.

## FR Instructions de montage des supports antivibratiles

L'unité peut être dotée de kits supports antivibratiles en caoutchouc.

- éloigner de la zone de travail les personnes étrangères;
- s'assurer que le groupe n'est pas sous tension;
- soulever l'unité en suivant les indications figurant dans le manuel d'utilisation et d'entretien;
- poser l'unité sur des soutiens suffisamment résistants pour en supporter le poids;
- établir le modèle d'unité et le type de supports antivibratiles;
- positionner soigneusement l'unité dans son logement.

## DE Montageanweisungen der Schwingungsdämpfer

Die Einheit kann mit einem Bausatz Schwingungsdämpfer aus Gummi ausgerüstet werden.

- Nicht zuständige Personen aus dem Arbeitsbereich verweisen;
- Prüfen, ob die Maschine noch unter Spannung steht;
- Unter Befolgung der Gebrauchs- und Wartungsanweisungen die Einheit anheben;
- Die Einheit auf solide Halterungen, die das Gewicht aushalten, abstellen;
- die Einheit und den Typ der Schwingungsdämpfer bestimmen ;
- die Einheit mit grösster Vorsicht in ihren Sitz bringen.

## ES Instrucciones de montaje de los soportes antivibrantes

La unidad se puede equipar con soportes antivibrantes de goma.

- Alejar de la zona de trabajo a las personas ajenas al mismo;
- cerciorarse de que la máquina no está alimentada eléctricamente;
- subir la unidad siguiendo las indicaciones incluidas en el manual de uso y mantenimiento de la misma;
- colocar la unidad en soportes sólidos capaces de aguantar su peso;
- buscar cuál es la unidad y el tipo de soportes antivibrantes;
- colocar la unidad con el máximo cuidado en su alojamiento.

**COMPONENTI DEL MARTINETTO** **fig.1**

**JACK COMPONENTS** **fig.1**

- E1 Grano M16x100mm con sede per chiave a brugola del 8.  
M16x100mm grub screw with lodging for HEX Key 8 .
- E2 - E6 Dado basso UNI 5589.  
Nut UNI 5589.
- E3 Rondella elastica spaccata UNI 1751.  
Broken elastic washer UNI 1751.
- E4 Disco in acciaio Inox 316 - Ø esterno 80 foro 17 e sp. 5 mm  
per grano M16.  
Steel-Disc in Made in stainless AISI 316 - Ø 80 sp.5 for M16 jack.
- E5 Dado alto UNI 5587.  
Nut UNI 5587.



Configurazione del martinetto prima dell'inserimento sull'antivibrante

Configuration of the jack before the insertion of the anti-vibrators.



Chiave a brugola del 8  
"Allen key" of the 8<sup>TH</sup>

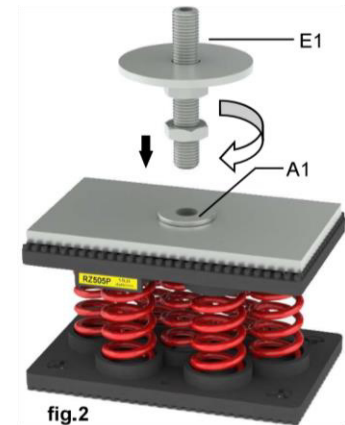


Chiave del 24  
"simple key" of the 24<sup>TH</sup>

**PROCEDURA PER L'INSERIMENTO DEL MARTINETTO SULL'ANTIVIBRANTE.**

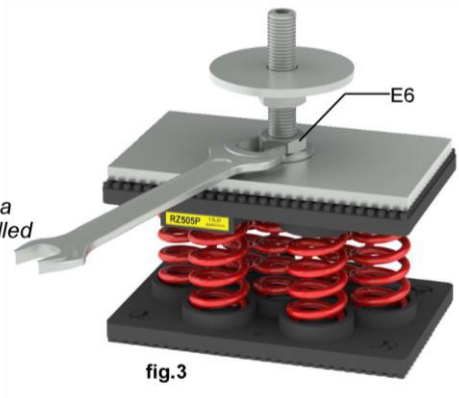
**Jack installation procedure**

**fig.2** Utilizzando la chiave a brugola del 8 avvitare il grano M16x100mm (E1) nella sede filettata presente sulla piastra di testa per circa 20-25mm (A1).  
Insert the M16x100mm grub screw (E1) in the threaded hole of the mount (upper plate) Screw the M16x100mm for 20-25mm (A1) using a 8 mm Hex key.

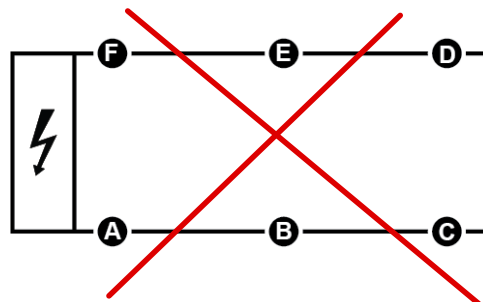
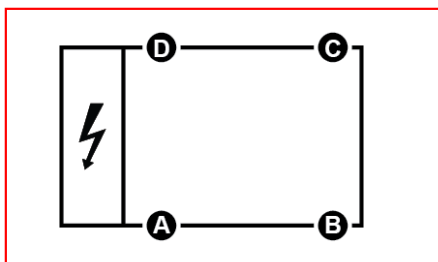
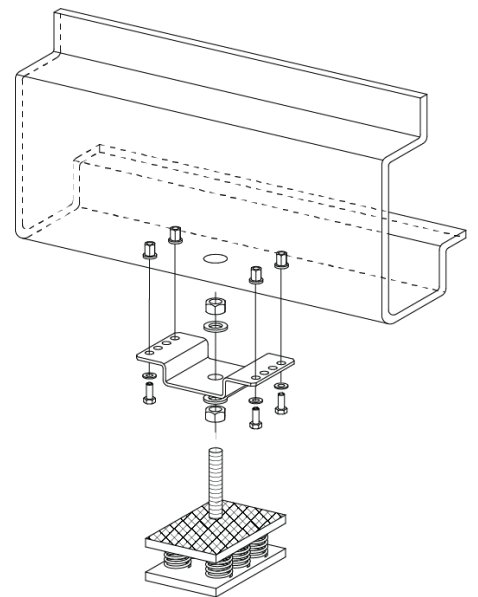
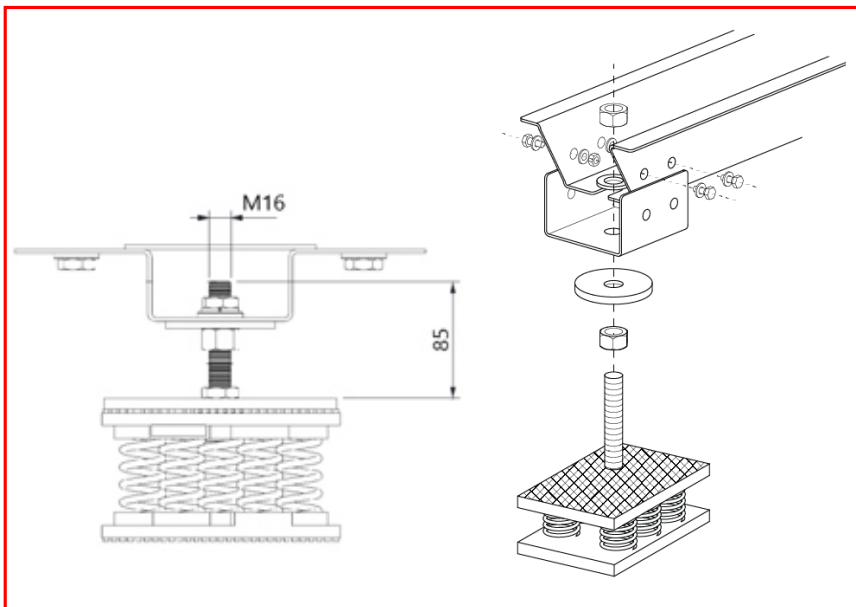
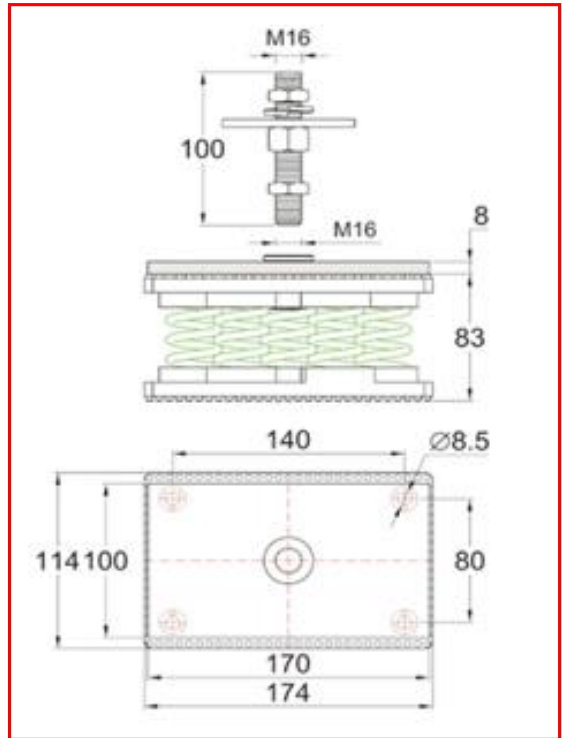


**fig.3** Utilizzando la chiave del 24 per M16, bloccare con il dado basso (E6) il grano M16 (E1), sulla piastra superiore.  
L'antivibrante così configurato è pronto per essere installato come indicato nella pagina seguente.

To fix the M16 grain on the upper plate tighten the steel nut (E6) using a 24 mm wrench (E1). The anti-vibration mount is now ready to be installed as shown in the next page.



TIPO / TYPE RXr - RZr



**DISTRIBUZIONE DEI PESI / WEIGHT DISTRIBUTION / DISTRIBUTION DES POIDS**

**GEWICHTSVERTEILUNG / DISTRIBUCIÒN DE LOS PESOS**

**WINFLOW MOTOEVAPORANTE 4185-4395kW**

	TAGLIA	4185	4210	4240	4275	4305	4350	4395
<b>SAM1</b>	<b>Kg</b>	<b>1040</b>	<b>1050</b>	<b>1070</b>	<b>1245</b>	<b>1390</b>	<b>1430</b>	<b>1445</b>
	A	295	298	302	371	436	445	461
	B	316	318	330	412	451	472	495
	C	222	224	229	244	256	264	253
	D	207	210	209	218	247	249	236
<b>SAM2 P/DP</b>	<b>Kg</b>	<b>1470</b>	<b>1480</b>	<b>1500</b>	<b>1710</b>	<b>1855</b>	<b>1925</b>	<b>1950</b>
	A	298	300	306	372	430	440	445
	B	288	290	296	353	387	403	409
	C	242	243	248	290	302	321	326
	D	191	192	194	203	198	212	214
	E	224	225	226	242	254	263	267
	F	227	230	230	250	284	286	289

	TAGLIA	4185	4210	4240	4275	4305	4350	4395
<b>SAM1</b>	<b>KIT</b>	<b>H5955001</b>			<b>H5955002</b>			
	A	RZr 405-Xr302	RZr 405-Xr302	RZr 405-Xr302	RZr 608-Xr103	RZr 608-Xr103	RZr 608-Xr103	RZr 608-Xr103
	B	RZr 508-205	RZr 508-205	RZr 508-205	RZr 608-Xr107	RZr 608-Xr107	RZr 608-Xr107	RZr 608-Xr107
	C	RZr 405-Xr302	RZr 405-Xr302	RZr 405-Xr302	RZr 405-Xr202-Xr103	RZr 405-Xr202-Xr103	RZr 405-Xr202-Xr103	RZr 405-Xr202-Xr103
	D	RZr 505-203	RZr 505-203	RZr 505-203	RXr 502-Zr203	RXr 502-Zr203	RXr 502-Zr203	RXr 502-Zr203
<b>SAM2 P/DP</b>	<b>KIT</b>	<b>H5955003</b>			<b>H5955004</b>			
	A	RXr 502-Zr205	RXr 502-Zr205	RXr 502-Zr205	RZr 608-Xr103	RZr 608-Xr103	RZr 608-Xr103	RZr 608-Xr103
	B	RXr 502-Zr205	RXr 502-Zr205	RXr 502-Zr205	RZr 608-Xr103	RZr 608-Xr103	RZr 608-Xr103	RZr 608-Xr103
	C	RXr 601-Zr108	RXr 601-Zr108	RXr 601-Zr108	RXr 602-Zr108	RXr 602-Zr108	RXr 602-Zr108	RXr 602-Zr108
	D	RXr 501-Zr203	RXr 501-Zr203	RXr 501-Zr203	RXr 401-Zr305	RXr 401-Zr305	RXr 401-Zr305	RXr 401-Zr305
	E	RXr 601-Zr108	RXr 601-Zr108	RXr 601-Zr108	RXr 502-201	RXr 502-201	RXr 502-201	RXr 502-201
	F	RXr 601-Zr108	RXr 601-Zr108	RXr 601-Zr108	RXr 502-201	RXr 502-201	RXr 502-201	RXr 502-201